

Time-frequency based Wavelet Transform Function for detection of Power quality disturbances: A Review

Tausif A. Mohammad

ME Student, Department of Electrical Engineering, Amravati University, Amravati.

M. R. Salodkar

Assistant professor ,Department of Electrical Engineering, GHRCE&M , Amravati University, Amravati

Abstract – With the increase of non-linear load such as a range of electronic and microprocessor base equipment power quality becomes the prominent issue now a day. In order to improve the power quality problem, detection of power quality problem must be done first. This paper presents a literature review of the application of wavelet transforms in the detection and analysis of power quality disturbances. The PQ disturbances include wide range of PQ phenomena namely transient (impulsive and oscillatory), short duration variations (interruption, sag and swell), power frequency variations, long duration variations (sustained under voltages and sustained over voltages) and steady state variations (harmonics, notch, flicker etc.) with time scale ranges from tens of nanoseconds to steady state in this condition extraction become difficult task. This paper presents a comprehensive review of different techniques based on wavelet transform to detect and classify power quality problems and advantages of wavelet transform over other signal processing tools.

Index Terms - Power quality, wavelet transform, discrete wavelet transform, multi-resolution analysis.

1. INTRODUCTION

POWER QUALITY (PQ) is becoming prevalent and of critical importance for power industry recently. The fast expansion in use of power electronics devices led to a wide diffusion of nonlinear, time-variant loads in the power distribution network, which cause massive serious power quality problems. At the same time, the wide use of accurate electronic devices require extremely high quality power supplies. According to the data provided by Electrical Power Research Institute (EPRI), the US economy is losing between \$104 billion and \$164 billion a year to outages, and another \$15 billion to \$24 billion to PQ phenomena [1] Therefore, the research of power quality issues has captured exponentially increasing attention in the power engineering community in the past decade.

Therefore, these days, customers demand higher levels of PQ to ensure the proper and continued operation of such sensitive equipments. According to IEEE standard 1159-1995 , the PQ

disturbances include wide range of PQ phenomena namely transient (impulsive and oscillatory), short duration variations (interruption, sag and swell), power frequency variations, long duration variations (sustained under voltages and sustained over voltages) and steady state variations (harmonics, notch, flicker etc.) with time scale ranges from tens of nanoseconds to steady state. A number of causes of transients can be identified: lightning strokes, planned switching actions in the distribution or transmission system, self-clearing faults or faults cleared by current limiting fuses, and the switching of end-user equipment. Transient phenomena are extremely critical since they can cause over voltages leading to insulation breakdown or flashover. These failures might trip any protection device initiating a short interruption to the supplied power. Excess current produced by transients may lead to complete damage to system equipment during the transient period. Moreover, if such disturbances are not mitigated, they can lead to failures or malfunctions of various [2-3] .

So there is a need of a reliable technique for monitoring the disturbances. To monitor power quality disturbances there are several methods are used like Fourier transform, short time Fourier transform[4]. In these various methods the wavelet transform is the best method suited for power quality disturbance detection . Fourier transform can't track the system dynamics properly because it can be applied only to the steady state phenomenon and it can't analyze the signal in both time and frequency domain. Whereas short time Fourier transform is not suitable for non stationary signals due to the limitations of a fixed window width. Thus STFT can't be used to analyze transient signals consisting both low and high frequency component. On the other hand wavelet transform is the best suited transform to analyze the signal in both time and frequency domain [5]. It provides the unique framework for monitoring the power quality problem. Recent advances in the wavelet transforms provide a powerful tool for power quality analysis [4][5][6].

1.1. POWER QUALITY DISTURBANCE CLASSES

There are various types of events that can degrade power quality, which makes the identification problems often elusive and difficult. In this paper detection algorithm was developed based on disturbance events from six major categories, which are as follow:

1. Sag / Under voltage
2. Swell / Over voltage
3. Waveform distortion
 - (a) Harmonic
 - (b) Harmonic with sag
 - (c) Harmonic with swell
 - (d) Notching
4. Transients
 - (a) Oscillatory Transient
 - (b) Impulsive Transient or Spike
5. Interruptions
6. Voltage fluctuations/Flicker

1.2 DRAWBACKS OF SIGNAL PROCESSING TECHNIQUES USED IN PQ DISTURBANCE

Various signal processing techniques used in power quality disturbances field are briefly discussed in the following subsections [2].

1. Although rms (Root Mean Square) is not an inherent signal processing technique, yet it is the most used tool. Rms gives a good approximation of the fundamental frequency amplitude profile of a waveform. A great advantage of this algorithm is its simplicity, speed of calculation and less requirement of memory, because rms can be stored periodically instead of per sample [10]. However, its dependency of window length is considered as a disadvantage. One cycle window length will give better results in terms of profile than a half cycle window. Moreover, rms does not distinguish fundamental frequency, harmonics or noise components. On the other hand, rms voltage profiles are used for event analysis and automatic classification as proposed in [11].

2. A great quantity of work has been focused in the estimation of amplitude and phase of the fundamental frequency as well as its related harmonics. A primary tool for estimation of fundamental amplitude of a signal is the DFT (Discrete Fourier Transform) or its computationally efficient implementation called FFT (Fast Fourier Transform). FFT transforms the signal from time domain to the frequency domain. Its fast computation is considered as an advantage. With this tool, it is possible to have an estimation of the

fundamental amplitude and its harmonics with a reasonable approximation. However, window dependency resolution is a disadvantage. e.g. longer the sampling window better the frequency resolution. FFT performs well for estimation of periodic signals in stationary state; however it doesn't perform well for detection of suddenly or fast changes in waveform e.g. transients, voltages dips or interharmonics. In some cases, results of the estimation can be improved with windowing or filtering, e.g. hanning window, hamming window, low pass filter or high pass filter.

3. A combination of QMFs (Quadrature Mirror Filters) arranged in binary trees is called filter banks. Filter banks have been used to study in more detail a specific sub band of the frequency spectrum. This technique was used in different applications to detect rapid changes in the waveform or for estimation of specific sub-band components, e.g. harmonic contents between 500 to 1000 Hz, capacitor switching or transients.

4. A well-known technique is the so-called Kalman Filter. This technique is defined as a state space model for tracking amplitude and phase of fundamental frequency and its harmonics in real time under noisy environment, which was proposed in [11]. Since then, many applications have come up, frequency estimation under distorted signals [12], detection of harmonics sources and optimal localization of power quality monitors [13].

5. In 1994, the use of wavelets was proposed to study power systems non-stationary harmonics distortion [9]. This technique is used to decompose the signal in different frequency sub-bands and study separately its characteristics.

6. Finally, the STFT (Short Time Fourier Transform) is commonly known as a sliding window version of the FFT, which has shown better results in terms of resolution and frequency selectivity. However, STFT has a fixed frequency resolution for all frequencies, and has shown to be more suitable for harmonic analysis of voltage disturbances than binary tree filters or wavelets when is applied to study voltage dip [14].

Latest advances in electrical power quality mitigation techniques are based on extraction of disturbances data instead of traditional methods. Hence time-frequency analysis is more suitable to detect disturbances from data. PQ disturbances also vary in a wide range of time and frequency, and (WT) Wavelet transformation has unique ability to examine the signal in time and frequency ranges at the same time which makes WT a best suited tool for power quality disturbances [15-16].

Traditionally, the Fourier transform permits mapping signals from time domain to frequency domain by decomposing the signals into several frequency components. This technique is

criticized in that the time information of transients is totally lost, although the accuracy of frequency components is high. Fourier transform does not fit the analysis of transients owing to the non-stationary property of its signals in both time and frequency domains. Wavelet transform generally offers this facility [17-21].

From the detailed studies of literature survey [9, 14-21] it is clear that several papers have been presented proposing the use of WT (Wavelet Transform) or ANN (Artificial Neural Network) or both for PQ disturbances. PQ disturbances have been defined into seven categories. The most focusing point of research is on few types of disturbance like, transients, SDVV (Short Duration Voltage Variations), or LDVV (Long Duration Voltage Variations). The important type of PQ disturbances “waveform distortion” have not been fully addressed or focused. DC offset, harmonics, interharmonics, notching and noise are five major disturbances. Software based novel approach technique for detection of PQ disturbances by time and frequency analysis with wavelet transform is proposed. This approach detects PQ problems of waveform distortion.

2. WAVELET TRANSFORMATION TECHNIQUE

The wavelet transform represents signal as a sum of wavelets at different locations (positions) and scales (duration). The wavelet coefficients work as weights of the wavelets to represent the signal at these locations and scales. The wavelet transform can be accomplished three different ways. The *Continuous Wavelet Transform (CWT)* where one obtains the surface of the wavelet coefficients, for different values of scaling and translation factors. It maps a function of a continuous variable into a function of two continuous variables.

The second transform is known as the *Wavelet Series (WS)* which maps a function of continuous variables into a sequence of coefficients. The third type of wavelet transform is the *Discrete Wavelet (DWT)*, which is used to decompose a discretized signal into different resolution levels. It maps a sequence of numbers into a different sequence of numbers [3, 4, 18, 20,21].

2.1 WHY DISCRETE WAVELET TRANSFORM

The continuous wavelet transform was developed as an alternative approach to the short time Fourier transforms to overcome the resolution problem. The important point to note here is the fact that the computation is not a true continuous wavelet. From the computation at finite number of location, it is only a discretized version of the continuous wavelet. Note, however, that this is not discrete wavelet transform (DWT). These days, computers are used to do almost all computations. It is evident that neither the FT, nor STFT, nor the CWT can be practically computed by using analytical equations, integrals, etc. It is therefore necessary to discretize

the transforms. As the discretize CWT enables the computation of the continuous wavelet transform by computers, it is not a true discrete transform. As a matter of fact, the wavelet series is simply a sampled version of the CWT, and the information it provides is highly redundant as far as the reconstruction of the signal is concerned. This redundancy, on the other hand, requires a significant amount of computation time and resources. The discrete wavelet transform DWT provides sufficient information both for analysis and the synthesis of the original signal, with a significant reduction in the computation time. The DWT is considerably easier to implement when compared to the CWT.

Wavelet analysis deals with expansion of functions in terms of a set of basis functions like Fourier analysis. However, wavelet analysis expands functions not in terms of trigonometric polynomials but in terms of wavelets, which are generated in the form of translations and dilations of a fixed function called mother wavelet. Comparing with FT, wavelet can obtain both time and frequency information of signal, while only frequency information can be obtained by Fourier transform [3, 4, 18, 20,21]. The signal can be represented in terms of both the scaling and wavelet functions as follows:

$$F(t) = \sum_n C_j(n) \varphi(t-n) + \sum_n \sum_{j=0}^{J-1} d_j(n) 2^{j/2} \psi(2^j t - n) \quad (1)$$

Where C_j is the J level scaling coefficient,

d_j is the j level wavelet coefficient,

$j(t)$ is the scaling function,

$\psi(t)$ is wavelet function,

J is the highest level of wavelet transform,

t is time.

Each level is created by scaling and translation operations in a special function called mother wavelet. A mother wavelet is a function that oscillates, has finite energy and zero mean value.

Wavelet theory is expressed by continuous wavelet transformation as

$$CWT_{x(a,b)} = W(a,b) = \int_{-\infty}^{\infty} x(t) \psi(t) a, b dt \quad (2)$$

where $\psi_{a,b}(t) = |a|^{-1/2} \psi((t-b)/a)$, a (scale) and b (translation) are real numbers.

Equation (2) has great theoretical interest for the development and comprehension of its mathematical properties. However, its discretization is necessary for practical applications. For discrete-time systems, the discretization process leads the time discrete wavelet series as

$$DWT_{\psi} x(m,n) = \int_{-\infty}^{\infty} x(t) \Psi_{a,b}(t) dt$$

$$\Psi_{m,n}(b) = a_0^{-m/2} \Psi((t - nb_0 a_0^m)/a_0^m)$$

Where $a = a_0^m$, $b = nb_0 a_0^m$ (3)

DWT provides a time and frequency representation of the recorded power quality signals. This is a very attractive feature in analysing time series because time localization of spectral components can be obtained. Classical methods of signal processing depend on an underlying notion of stationary, for which methods such as Fourier analysis are very well adapted. In power quality researches, however, more properties other than stationary are required, and thus make the DWT application more appropriate than Fourier transform. The goal of MRA is to develop representations of a signal at various levels of resolution. MRA is composed of two filters in each level which are low pass and high pass filter. MRA can detect and diagnose defects, and provide early warning of power quality problems. Power quality problems are characterized by their maximum amplitudes, crest voltages, RMS, frequency, statistics of wavelet coefficients, instantaneous voltage drops, number of notches, duration of transients, etc. These characteristics are unique identifying features or different power quality problems and introduced signal processing tools in power quality analysis [3, 4, 18, 20,21].

2.2 DISCRETE WAVELET TRANSFORM ALGORITHM

In Multiresolution analysis (MRA), wavelet functions and scaling of functions are used as building blocks to decompose and reconstruct the signal at different resolution levels. The wavelet functions will generate the detail version of the decomposed signal and the scaling function will generate the approximated version of the decomposed signal. MRA refers to the procedures to obtain low-pass approximations and high-pass details from the original signal. An approximation contains the general trend of the original signal while a detail embodies the high-frequency contents of the original signal. Approximations and details are obtained through a succession of convolution processes. The original signal is divided into different scales of resolution, rather than different frequencies, as in the case of Fourier analysis. The maximum number of wavelet decomposition levels are determined by the length of the original signal and the level of detail required. Details and approximations of the original signal are obtained by passing it through a filter bank, which consists of low and high-pass filters. A low pass filter removes the high frequency components, while the high pass filter picks out the high-frequency contents in the signal being analysed [3, 4, 16, 18,19].

The synthesized signal is decomposed into its constituent wavelet sub-bands. Each of these bands represents that part of original signal occurring at that particular frequency. If the

original signal is being sampled at 10 KHz, then the highest frequency that the sampled signal would faithfully represent is 5 KHz (Based on the Nyquist theorem). Detecting the disturbances interval is one of the suitability of WT in the field of electrical PQ. To apply wavelet to identify time intervals of disturbances following steps are taken:

- (i) Generate a signal with actual data or developed in any software with known initial and final times.
- (ii) Apply different wavelet transform with suitable mother wavelet.
- (iii) Identify the disturbances intervals with the help of wavelet coefficients.

2.2.1 Choice of Analyzing Mother Wavelet

Choice of analyzing mother wavelets plays a significant role in detecting various types of power quality disturbances. Especially when considering small scale signal decompositions. For fast and short transient disturbances, Daub4 (called as Daubechies 4) and Daub6 wavelets are better, while for slow and long transient disturbances, Daub8 and Daub10 are particularly suitable. Selection of an appropriate mother wavelet for all types of PQ disturbances is very important, instead of creating algorithms to select different appropriate wavelets for different

problems [3, 20,21].

At the lowest scale like scale 1, the mother wavelet is most localized in time and oscillates most rapidly within a very short period of time. As the wavelet goes to higher scales, the analyzing wavelets become less localized in time and oscillate less due to the dilation nature of the wavelet transform analysis. As a result of higher scale signal decomposition, fast and short transient disturbances will be detected at lower scales, whereas slow and long transient disturbances will be detected at higher scales.

2.3.MULTIRESOLUTION ANALYSIS

Multiresolution analysis technique of wavelet is used in analysis of waveforms and images [9]. Wavelet functions and scaling functions are used as building blocks to decompose and reconstruct the signal at different resolutions in Multi Resolution Analysis (MRA). In MRA two filters scheme is utilized in each level, in which one is low pass filter and another is high pass filter shown in figure below,

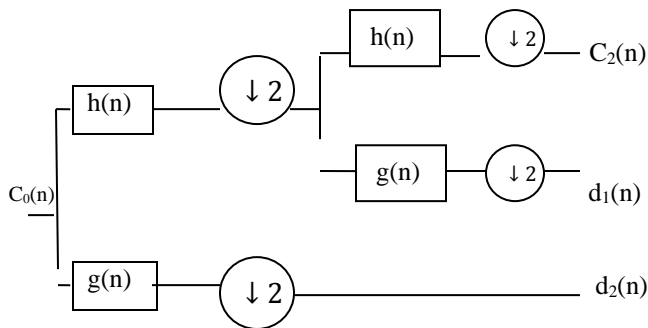

Figure 1. Multi resolution Analysis

Let the signal ($C_0(n)$) is discrete time signal scattered in two levels. This signal is filtered into low frequency component level 1 ($C_1(n)$) by using low pass filter ($h(n)$) and into high frequency component level 1 ($d_1(n)$) by using high pass filter ($g(n)$). This signal is then passed through down sampling this can be shown by the relation given in eq.(4)-(5).

$$C_1(n) = \sum_k h(k - 2n) C_0(k) \quad (4)$$

$$d_1(n) = \sum_k g(k - 2n) C_0(k) \quad (5)$$

$g(n)$ and $h(n)$ are high pass and low pass filters respectively.

The component obtained after level MRA analysis level 1 will be initial signal for MRA level 2. This signal is then passed through low pass filter and high pass filter. The filter's output are the high frequency component in level

2 as relation in eq.(6)-(7).

$$C_2(n) = \sum_k h(k - 2n) C_1(k) \quad (6)$$

$$d_2(n) = \sum_k g(k - 2n) C_1(k) \quad (7)$$

In [9] the author proposed a wavelet Multi-Resolution Analysis (MRA) technique based model which was used to decompose the signal into various details and approximation signals, and unique features from the 1st, 4th, 7th and 8th level detail are obtained as criteria for classifying the type of disturbance occurred.

2.4.. APPLICATION OF WAVELET TRANSFORM IN OTHER FIELDS OF POWER SYSTEM

Wavelet transform has been implemented in following several fields of power system in last few years

- Power quality

- Power system protection
- Power system transients
- Partial discharge
- Load forecasting
- Power system measurements.

3. PORPOSED MODELLING

It is very importance for safe running of electric power system to detect and classify PQ disturbances. There are mainly two tasks for detection and classification of PQ disturbances, one is extracting features, and other is recognition and classification. Wavelet transform is one of the signal processing technique which has the ability to analyze power quality problem simultaneously both time and frequency domain. The energy signatures extracted from wavelet coefficient are used to detect and localize the disturbances from the recorded voltage waveform. The disturbances of interest include sag, swell, sag and swell with Harmonic. The Proposed method of power Quality analysis is shown in fig 2.

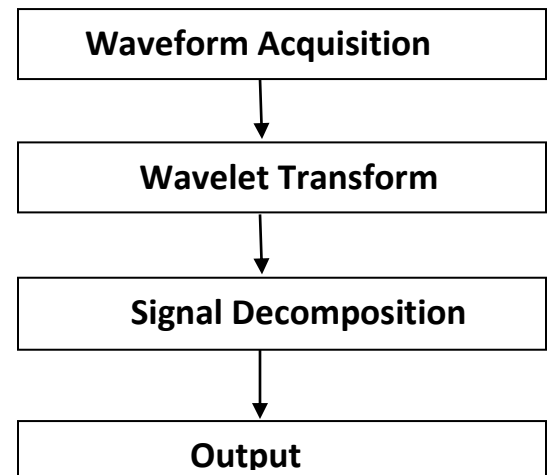

Figure.2

The starting point of Analysis is the simulation of power disturbances Viz.

- Sinusoidal Signal.
- Sinusoidal signal with intermediate sag.
- Sinusoidal signal with intermediate swell.
- Sinusoidal signal with intermediate Harmonic.
- Sinusoidal signal with intermediate sag with Harmonic.
- Sinusoidal signal with intermediate swell with Harmonic.

All these signal will be generated using MATALAB coding.

The next step is taking wavelet transform to localize the disturbances and detect the occurrence of disturbances. The next step is feature extraction to find the type of the event occurred. Multi resolution analysis technique [1] will be used to detect and localize different power quality problem. Furthermore, introduce standard deviation curve at different resolution levels. In the proposed method, disturbances detection and localization is performed in the wavelet domain. Using multiresolution signal decomposition technique one can decompose the distorted signal into different resolution levels. However the mentioned approach dealt with power quality problem, it does not present a real classification methodology that can be used to classify different power quality problems.

4. CONCLUSIONS

A Wavelet Transform technique for analysis of PQ disturbances is presented in this paper. Waveform distortion type of PQ disturbances has been discuss and deliberated. Different types of signals are generated and different frequency bands are obtained in the process of computation. It is noted that choice of suitable mother wavelet is vital to detect PQ disturbances. It is concluded that the use of approximate coefficients and scaling, makes detection of PQ disturbances easier. The computational results have shown that Wavelet Transform is a suitable tool to examine PQ disturbances, when time-frequency information is required simultaneously.

REFERENCES

- [1] Haibo He, Janusz A. Starzyk, "A Self Organising Learning Array System for Power Quality Classification Based on Wavelet Transform," *IEEE Transactions On Power Delivery*, Vol. 21, No. 1, pp. 286-295, January.
- [2] Devendra Mittal et al "Classification of Power Quality Disturbances in Electric Power System: A Review," *IOSR Journal of Electrical and Electronics Engineering (IOSR-JEEE)* ISSN: 2278-1676 Volume 3, Issue 5 (Nov. - Dec. 2012), PP 06-14. www.iosrjournals.org.
- [3] *IEEE Standards Board, IEEE Std. 1159-1995, IEEE Recommended Practice for Monitoring Electric Power Quality (New York: IEEE, Inc. June, 1995).*
- [4] P.K.Dash, B.K.Panigrahi and G.Panda, "Power Quality Analysis using S Transform," *IEEE Transaction on Power Delivery*, Vol.18, No.2, pp 406-411, April 2003.
- [5] D. P. Mishra "Sag, Swell and Interruption Detection Using Wavelet in LabVIEW" *International Journal of Computer and ElectricaEngineering*, Vol. 5, No. 4, August 2013.
- [6] Olivier Poisson et al, "Detection and Measurement of Power Quality Disturbances using Wavelet Transform", *IEEE Transaction on Power Delivery*, Vol.15, No.3, pp 1039-1044, July 2000.
- [7] Haili Ma and Adly Girgis, "Identification and Tracking of Harmonics Sources in a Power System Using Kalman Filter", *IEEE Transactions on Power Delivery*, Vol. 11, No.3, July 1996.
- [8] P. Ribeiro, "Wavelet Transform: An Advanced Tool for Analyzing Non Stationary Harmonic Distortion in Power Systems", *Proceeding of IEEE International Conference On Harmonics in Power Systems, 1994.*
- [9] A.M.Gauda et al, "Power Quality Detection and Classification using Wavelet Multiresolution Signal Decomposition," *IEEE Transactions On Power Delivery*, Vol.14, No. 4, pp. 1469-1476, October 1999.

- [10] P. Ribeiro, "Wavelet Transform: An Advanced Tool for Analyzing Non Stationary Harmonic Distortion in Power Systems", *Proceeding of IEEE International Conference On Harmonics in Power Systems, 1994.*
- [11] Irene Gu, Math Bollen, "Time Frequency and Timescale Domain Analysis of Voltage Disturbances", *IEEE Transactions on Power Delivery*, Vol. 15, No.4 October 2000.
- [12] Tongxin Zheng, Elham Makran and Adly Girgis, "Power System Transient and Harmonic Studies Using Wavelet Transform", *IEEE Transactions on Power Delivery*, Vol. 14, NO.4, October 1999.
- [13] Gerald Heydt and A. Galli, "Transient Power Quality Problems Analyzed using Wavelets", *IEEE Transactions on Power Delivery*, Vol. 12, No.2, April 1997.
- [14] Surya Santoso, Edward J. Powers, W. Mack Grady, Peter Hofmann, "Power Quality Assessment via Wavelet Transform Analysis", *IEEE transactions on Power Delivery*, Vol. 11, No.2, April 1996.
- [15] Ghosh, A., and Lubkeman, D., "The Classification of Power System Disturbance Waveforms Using a Neural Network Approach", *IEEE Trans. Power Deliv.*, 1995, 10, (1), pp. 109-115.
- [16] Catilla, M., Borrás, D., Moreno, N., and Montano, J., "Wavelet and Neural Network Structure for Analyzing and Classifying Power System Disturbances", *Proceedings of the European power electronics (EPE) conference, Lausanne, 1999.*
- [17] Penna, C., "Detection and Classification of Power Quality Disturbances Using the Wavelet Transform, M. Sc. Dissertation", June 2000, *University Federal de Uberlandia, Brazil.*
- [18] S. Santoso, J. P. Edward, W. M. Grady, and A. C. Parsons, "Power Quality Disturbance Waveform Recognition Using Wavelet-Based Neural Classifier—Part 1: Theoretical foundation," *IEEE Trans. Power Delivery*, Vol.15, pp. 222-228, Feb.2000.
- [19] Elmitwally, A.; Farghal, S.; Kandil, M.; Abdelkader, S.; Elkateb, M., "Proposed Wavelet-Neurofuzzy Combined System for Power Quality Violations Detection and Diagnosis," *Generation, Transmission and Distribution, IEE Proceedings*, Vol. 148 Issue: 1, Jan. 2001, pp. 15 -20
- [20] J. V. Wijayakulasooriya, G. A. Putrus, and P. D. Minns, "Electric Power Quality Disturbance Classification Using Self-Adapting Artificial Neural Networks," *Generation, Transmission and Distribution, IEE Proceedings*, Vol. 149, No. 1, pp. 98-101, Jan. 2002.
- [21] John Williams and Kevin Amaratunga "Introduction To Wavelets in Engineering", *International Journal for Numerical Methods in Engineering*, Vol.37. pp. 2365-2388, 1994.

Authors

Tausif A. Mohammad: He is doing M.E(Electrical Power System) in G.H.Raisoni college of Engineering & Management . He has completed his B.Tech from GC OE Amravati. His areas of research are power quality.

Mukund R. Salodkar: He is assistant Professor in the faculty of Electrical Engineering in G.H.Raisoni college of Engineering & Management. His research areas are power system stability and power quality.